

Universals in Multidimensional Translation



MuTra ‘LSP Translation Scenarios’

1 May 2007

0 Introduction

1 Problem and Phenomenon

2 Selected Universal Thought Principles and Translation & Interpreting

2.1 The Participant – Observer Dichotomy

2.2 The ICS Model

2.3 Three Text Perspectives

3 Applications & Perspectives

0 Introduction

The general thought principles discussed are the:

- **participant – observer dichotomy**
- **differentiation of individual, collective and systems levels of description (ICS)**
- **atomistic-hol-atomistic-holistic text perspective triad.**

Some of these principles will be applied by the doctoral presentations which will follow this lecture.

In line with the concept of the Marie Curie conference, these doctoral projects are presented by early stage and experienced scholars, some of the presentations will therefore present works that are finished and published, some of them are still at an earlier stage of a dissertation project.

1 Problem and Phenomenon

Translation Universals is the label for a research paradigm that is motivated by the question of whether there are general regularities and methodologies. Proposals for translation universals are about

- (a) the relationship between translations and source texts and
- (b) the relationship between translations and comparable non-translations in the target language.

Potential translation universals are quantitatively accessible as textual features of a “third code” or “translationese”

- **Simplification**
e.g.. less lexical variety, lower lexical density, less complex sentence structures
- **Explicitation**
i.e. introducing information into the target text
- **Normalization**
the translator's rendering of text features to conform to typical target text features

Translation Universals is strongly favored by corpus-based methodologies, largely pioneered by Mona Baker in the early 90s.



1 Problem and Phenomenon (cont.)

Corpus methodologies have their limitations in that

- qualitative criteria are neglected
e.g. cohesion shifts vs. coherence, cf. Blum-Kulka 1986
- individual text features that control translations are not collectively accessible
e.g. the translation purpose, but also the intended readership type, the translator's perceptions, competence and preferences

Few translation researchers have therefore suggested principles ‘outside’ the text:

- Chesterman (2004) cautions that the term ‘universal’ be restricted to claims that are actually hypothesized to be universal, not specific to a subset of concrete
- Toury underlines that translational behavior is affected by a vast heterogeneous array of factors and prefers to speak of “laws” rather than ‘universals’ (1995:268) and suggests that “the whole question of translation universals is not one of existence but one of explanatory power” (2004:29).

1 Problem and Phenomenon (cont.)

Against the background of this debate the principles of

- **participant – observer dichotomy**
- **individual, collective and systems levels of description (ICS) and**
- **atomistic-hol-atomistic-holistic text perspectives**

are presented here in their translational dimension with the intent of opening a discussion rather than providing all the answers.

2 Selected Universal Thought Principles and Translation & Interpreting

2.1 The Participant – Observer Dichotomy

We suggest that the differentiation of whether principles are formulated

- to be put to use (participants' view) or
- for detached onlookers (observers' view)

determinates the categories and methods used for building a theory.

For example:

- a bicycle can be described for a user (who is interested in riding the bike)

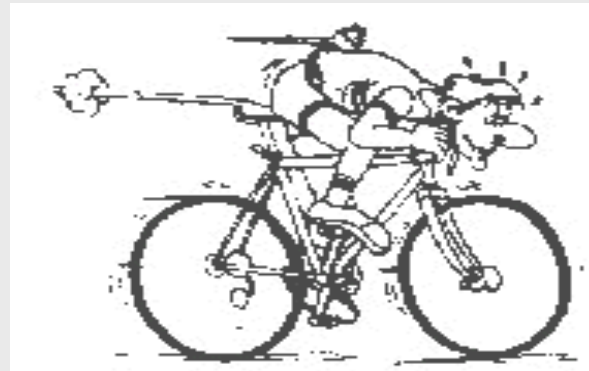

2.1 The Participant – Observer Dichotomy (cont.)

- or for someone interested in how it is put together.

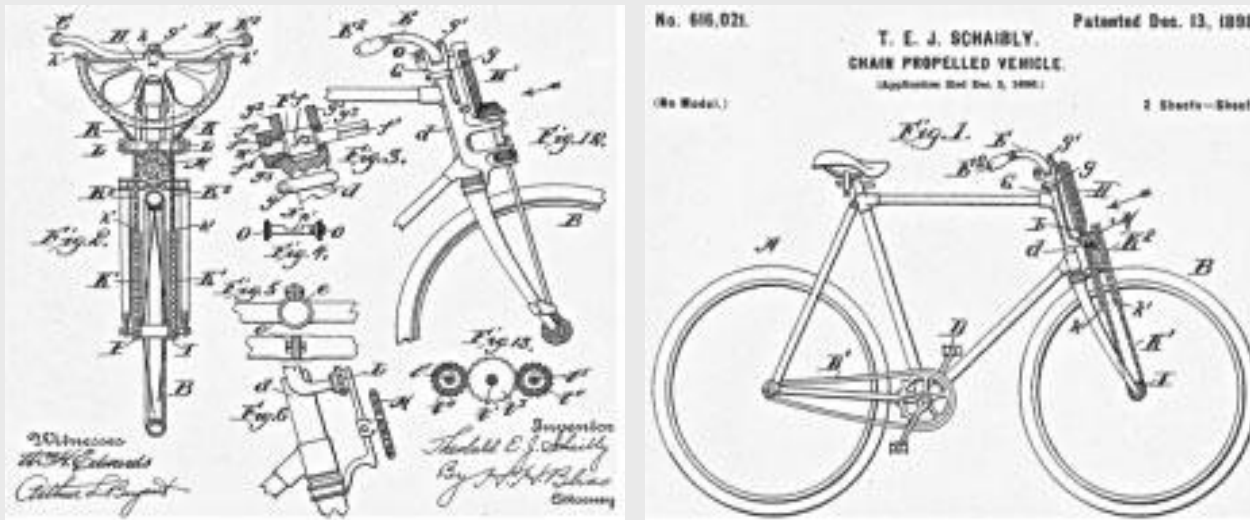

What information and how this information is presented is different for bicycle riders and bicycle developers or constructors. If you give the bicycle rider a list of bicycle components, she may be disappointed and not know what to do with it. If, on the other hand, you give bicycle riding instructions to a bicycle constructor, she may feel undervalued.

2.1 The Participant – Observer Dichotomy (cont.)

In translation theory, the lack of differentiating between the ‘participant’s and ‘observer’s views has led to the seemingly irreconcilable gap between theory and practice:

- Practicing translators (‘participants’) are interested in how to solve a particular translation problem, e.g.. translate culture in texts or to produce texts according to a specific purpose and will therefore appreciate a step-by-step methodology of how to proceed when faced with a particular problem and may feel frustrated when being served a hermeneutic circle no matter how fascinating it may be.
- ‘Observers’, on the other hand, will appreciate a cultural system and a discussion of how it is composed for contrastive descriptions and may feel misunderstood by what to them is simply a ‘how to’, ‘hands-on’ approach.

This problem of orienting one’s theoretical thought to active ‘participants’ or thoughtful ‘observers’ has contributed substantially to the theory – practice gap still ongoing today which so sadly prevents Translation from becoming a coherent discipline.

Operationalization

From Min Sunwoo:
Operationalizing the translation Purpose

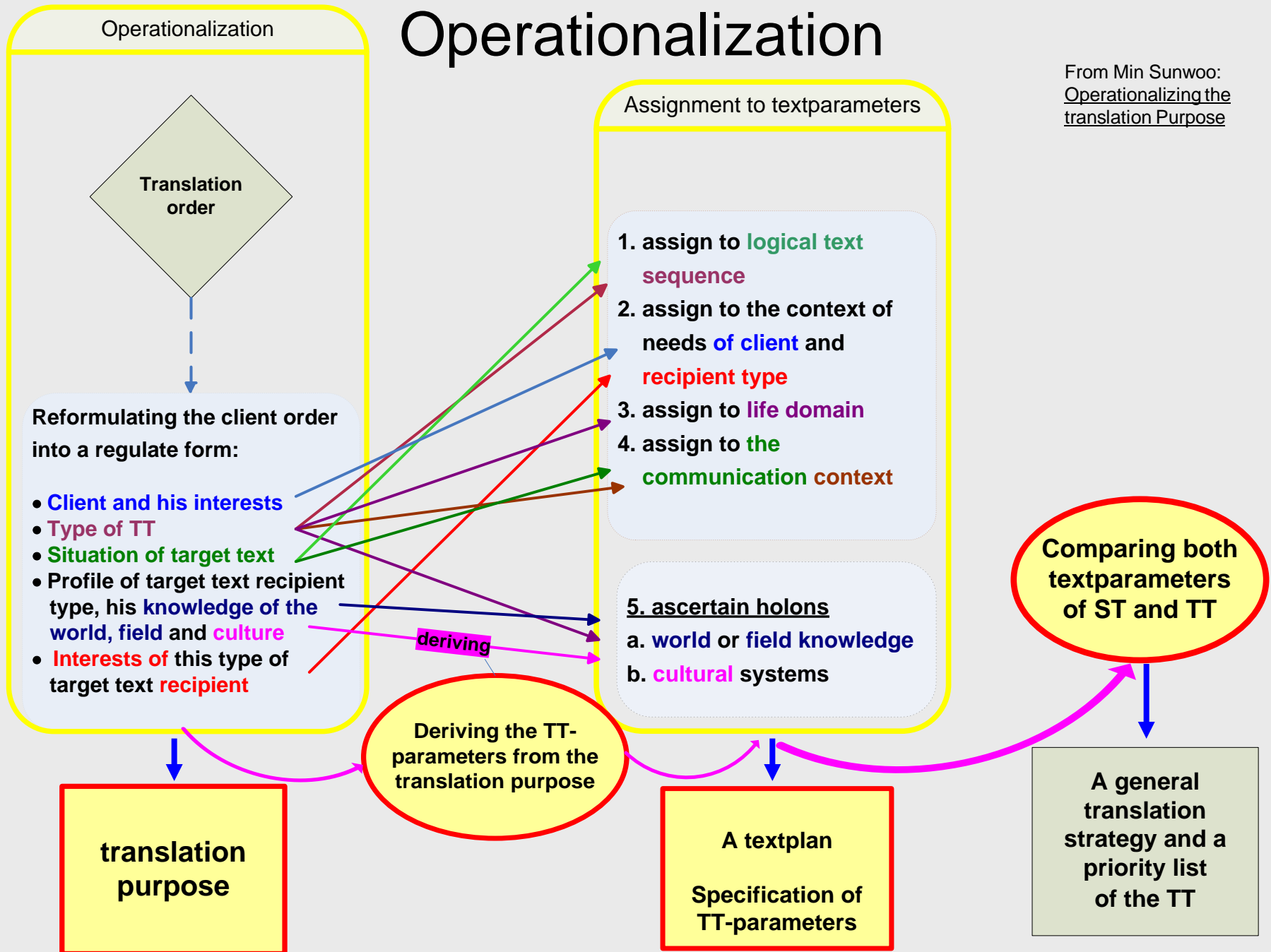

2 Selected Universal Thought Principles and Translation & Interpreting (cont.)

2.2 The ICS Model : Individual, Collective and Systems levels of description

The ICS model differentiates three general description levels on which research questions can be formulated, objects and data can be analyzed and theoretical models can be drafted and put to the test. These levels are:

- I** **an individual level (I-level)** on which (abstract or concrete) objects are investigated on the basis of a catalog of characteristics (parameters) with a specified range of values;
- C** **a collective level (C-level)** on which groups of (concrete and abstract) objects are statistically investigated relative to (a constellation of) parameters;
- S** **a systems level (S-level)** on which abstract objects and their characteristics are investigated. Objects under investigation on the systems level are non-existent as phenomena and are thus not accessible empirically.

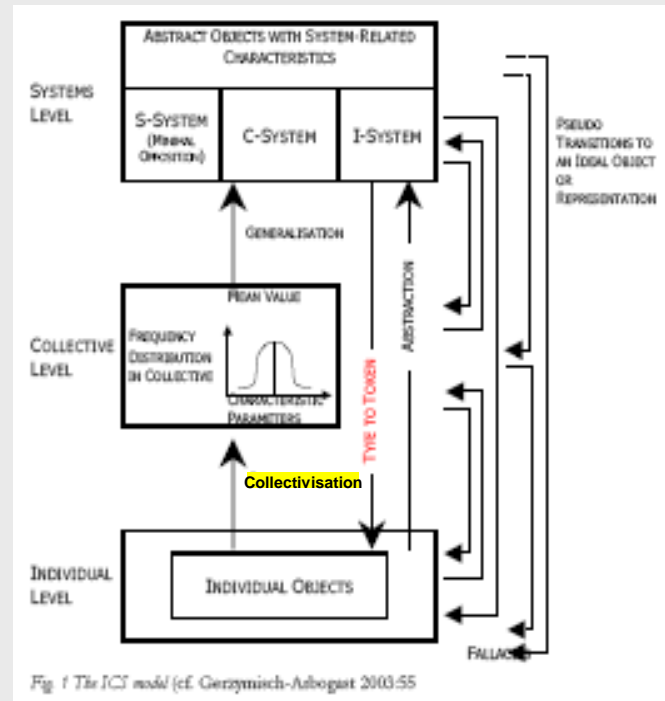

2.2 The ICS Model : Individual, Collective and Systems levels of description (cont.)

The ICS description levels are not isolated levels, but allow for interrelationships through so-called transitions.

Transitions between these levels are subject to certain conditions and lead to

- **constructive transitions**, yielding manifest results
- pseudo-transitions, yielding no manifest results, only seemingly offer solutions to research problems
- **and/or fallacies**, implying flaws in logical thinking and reasoning, and lead to false conclusions.

This overview shows the ICS and its transitions:

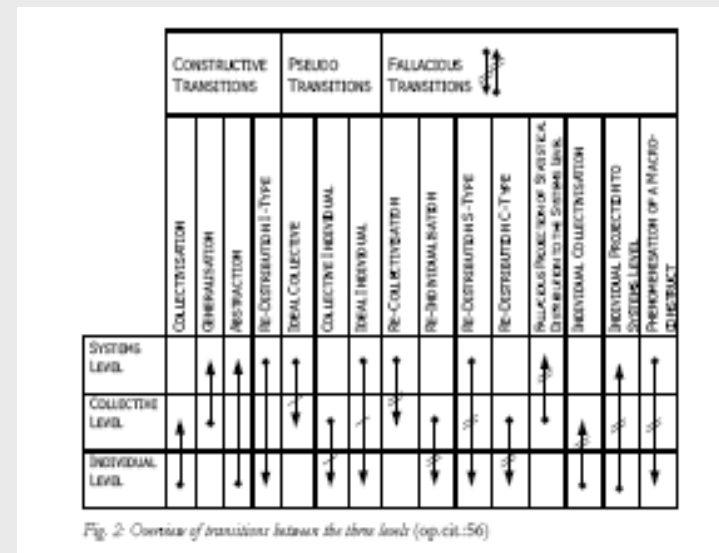

	CONSTRUCTIVE TRANSITIONS			PSEUDO TRANSITIONS			FALLACIOUS TRANSITIONS								
	Collectivisation	GENERALISATION	ABSTRACTION	RE-DISTRIBUTION I -TYPE	IDEAL COLLECTIVE	COLLECTIVE INDIVIDUAL	IDEAL INDIVIDUAL	RE-COLLECTIVISATION	Re-Individualisation	RE-DISTRIBUTION S-TYPE	RE-DISTRIBUTION C-TYPE	FALLACIOUS PROJECTION OF STATISTICAL DISTRIBUTION TO THE SAME LEVEL	INDIVIDUAL COLLECTIVISATION	INDIVIDUAL PROJECTION TO SYSTEMS LEVEL	PREHENSATION OF A MACRO-SUBJECT
SYSTEMS LEVEL		↑	↑	↑	↑		↑	↑		↑		↑	↑	↑	↑
COLLECTIVE LEVEL	↑	↓	↓	↓	↓	↓	↓	↓	↓	↓	↓	↓	↓	↓	↓
INDIVIDUAL LEVEL	↓		↓	↓		↓	↓		↓	↓	↓		↓	↓	↓

Fig. 2 Overview of transitions between the three levels (op.cit.:56)

2.2 The ICS Model : Individual, Collective and Systems levels of description (cont.)

While we cannot in this presentation show and discuss the full scope of the ICS and its transitions, there is one that is interesting to the discussion of translation universals, i.e. the

- **transition of collectivization and generalization**

and the related fallacies of

- **re. individualization of a C-type and**
- **re-distribution of an S-Type**

which we will briefly look at.

2.2 The ICS Model : Individual, Collective and Systems levels of description (cont.)

(A) Collectivisation (from **I** to **C**)

Principle:

The process of collectivization is a transition from the individual level of description (I-level) to the collective level of description (C-level).

It involves a collective as a basis of the investigation.

This collective is formed by a set established on the I-level by individual objects with identical values (= collective).

The thus established collective is then statistically investigated, yielding significant frequencies for certain parameters.

Applied to translation universals this means with reference to ‘explicitation’

- that a collective is formed by a set of individual texts (I-level) with identical values, e.g. additional information relative to cultural specifics
- the thus established collective is then statistically investigated, yielding a significant value for ‘explicitation’ of cultural specifics.

2.2 The ICS Model : Individual, Collective and Systems levels of description (cont.)

Re-Individualization – Problem:

The transition of collectivization is accompanied by a loss of information:

- The transition of a collectivization involves the individual level of (abstract or concrete) objects which are analyzed according to a catalogue of parameters (with a certain range of values).
- These parameter values must be different from object to object (= individualizing parameters) but may show the same parameter value in all objects (= characterizing parameters).

Individual objects within the same parameter range form a collective which differs from the extensional individual set of objects on the I-level in that the objects in the collective are ‘anonymized’ within the transition of collectivisation, i.e. when they are statistically investigated relative to a collective analysing parameter.

(Note that while the objects in the collective may still be individually accessible (for each object the parameter values are statistically investigated), the identity of the objects, their individual identifiability (via individualizing parameter values) is, however, not relevant for the statistical investigation.)

Re-Individualization – Problem: (cont.)

If a collective is formed, this process will result in an anonymization of objects:

- By anonymizing the objects via collectivization, the corresponding individual objects are no longer available. This means that the process of statistical analysis implies that the individual parameters are no longer available for further analysis.

Consequently, from the results of a statistical analysis no conclusions can be drawn with respect to the individual parameters of the individual objects in the collective.

(Re-Individualization = Fallacy)

A general example may illustrate this:

In Germany, the Bureau of Statistics conducts an investigation of the population with respect to certain parameters, among them family size, number of children, income level, etc. People are grouped together according to whether they have a family or are single. Those who have a family form a collective which can now be statistically investigated using a collective-analyzing parameter, e.g. ‘number of children’.

Applied to translation universals,

this means that by forming a collective of texts with the characterizing parameter ‘explicitation’, the individualizing parameters of these texts, e.g. ‘translation purpose’ or ‘intended readership’ are anonymized and no longer available for further analysis.

From Martin Will: Knowledge management in the simultaneous interpretation of LSP conferences

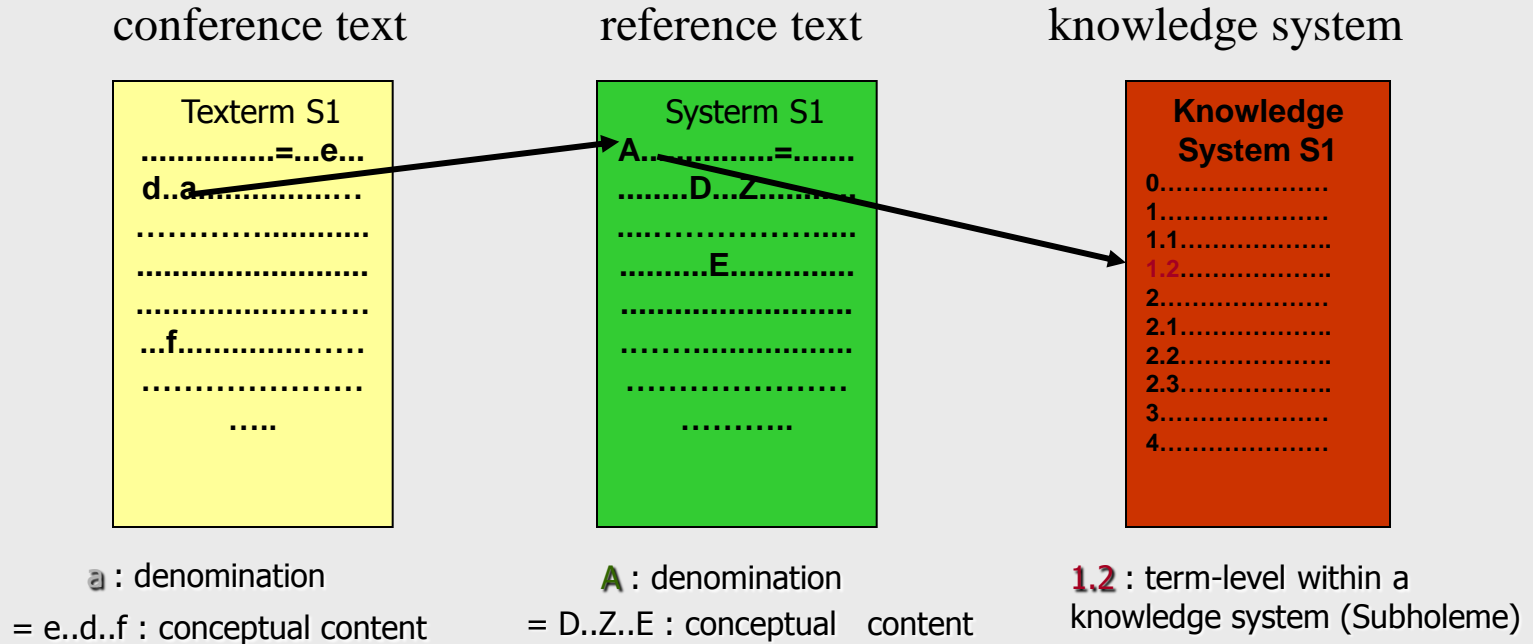

Fig. 1: Structured Terminological Knowledge Entity - monolingual

2 Selected Universal Thought Principles and Translation & Interpreting (cont.)

2.3 Three Text Perspectives

It is argued that texts and their translations can be viewed from different perspectives, i.e.

- 1) an **atomistic perspective** that views only individual components of a text put together to form the structure of a text, e.g. words like Lego components which form a structure or system,
- 2) a **hol-atomistic perspective** that takes the individual components further into the text and looks at their informational strings or semantic clusters and
- 3) a **holistic perspective** which looks at holistic ‘Gestalt’ phenomena, implied background knowledge, cultural attitudes and values in a text.

These perspectives lead to different translation methodologies, i.e. *Aspectra*, *Relatra* and *Holontra* .



2.3 Three Text Perspectives (cont.)

Analysis on the atomistic level accounts for ‘atomistic’, i.e. smallest individual text features, and may include all textual phenomena (from typographical idiosyncrasies, explicitness of reference, metaphorical diversity and/or cultural implications) that do not develop into more complex textual dimensions. They are identified, listed and systematized as text ‘aspects’ with different ‘values’ and correlated with respective text segments. The resulting aspective matrix allows for transparency of an individual reading and interpretation of a text in its atomistic dimension.

Visualization is by matrix form

\ Aspekte Textstellen	1. Terminologie	2. Syntax	3. Kohärenz	4. Begriffseinführung	5. Autor-Leser-Verhältnis	6. Sprecherindikatoren
	1.1 Vorhanden 1.2 Nicht-vorhanden	2.1 Nominalisierungen 2.2 Verbalkonstruktionen	3.1 mit Inferenzziehung 3.2 ohne Inferenzziehung	4.1 direkt 4.2 indirekt	5.1 inhaltsbezogen 5.2 leserbezogen	6.1 vorhanden 6.2 nicht vorhanden
0. Transactions Demand	1.1	—	3.1	—	5.1	6.2
1. People and firms need money as a transactions medium	1.1	2.1	3.1	—	5.2	6.2
2. Households need money to buy groceries and to pay for electricity and fuel bills as well as occasional large consumer durables.	1.1	2.2	3.2	—	5.2	6.2
3. Firms need money to pay for materials and labor.	1.2	2.2	3.2	—	5.2	6.2
4. These elements constitute the <i>transactions demand for money</i> .	1.1	—	3.1	4.2	5.1	6.2
5. We can illustrate the mechanics of the transactions demand for money in Fig. 16-2.	1.1	2.1	3.2	—	5.2	6.2
6. This figure shows the average money holdings of a family that earns \$ 1000 per month, keeps it in money, and spends it all evenly over the month.	1.1	2.2	3.1	—	5.2	6.2
7. Clearly, the family holds \$ 500 on average in money balances.	1.1	—	3.2	—	5.2	6.1

<div style="text-align: center;"> Aspekte Textstellen </div>		1. Terminologie	2. Syntax	3. Kohärenz	4. Begriffseinführung	5. Autor-Leser-Verhältnis	6. Sprecherindikatoren
		1.1 Vorhanden 1.2 Nicht-vorhanden	2.1 Nominalisierungen 2.2 Verbalkonstruktionen	3.1 mit Inferenzziehung 3.2 ohne Inferenzziehung	4.1 direkt 4.2 indirekt	5.1 inhaltsbezogen 5.2 leserbezogen	6.1 vorhanden 6.2 nicht vorhanden
0.	Transactions Demand	1.1	—	3.1	—	5.1	6.2
1.	People and firms need money as a transactions medium	1.1	2.1	3.1	—	5.2	6.2
2.	Households need money to buy groceries and to pay for electricity and fuel bills as well as occasional large consumer durables.	1.1	2.2	3.2	—	5.2	6.2
3.	Firms need money to pay for materials and labor.	1.2	2.2	3.2	—	5.2	6.2
4.	These elements constitute the <i>transactions demand for money</i> .	1.1	—	3.1	4.2	5.1	6.2
5.	We can illustrate the mechanics of the transactions demand for money in Fig. 16-2.	1.1	2.1	3.2	—	5.2	6.2
6.	This figure shows the average money holdings of a family that earns \$ 1000 per month, keeps it in money, and spends it all evenly over the month.	1.1	2.2	3.1	—	5.2	6.2
7.	Clearly, the family holds \$ 500 on average in money balances.	1.1	—	3.2	—	5.2	6.1

2.3 Three Text Perspectives (cont.)

The hol-atomistic level ‘mediates’ between the atomistic and holistic levels. Analysis on a hol-atomistic level identifies features in texts that extend from the isolated atomistic unit to a more complex dimension in the context of the text as a whole. Examples are the (linearity or digression of) information structures (theme-rheme analysis) or the quality and complexity of isotopic patterns .

Representation and visualization is by semantic networks.

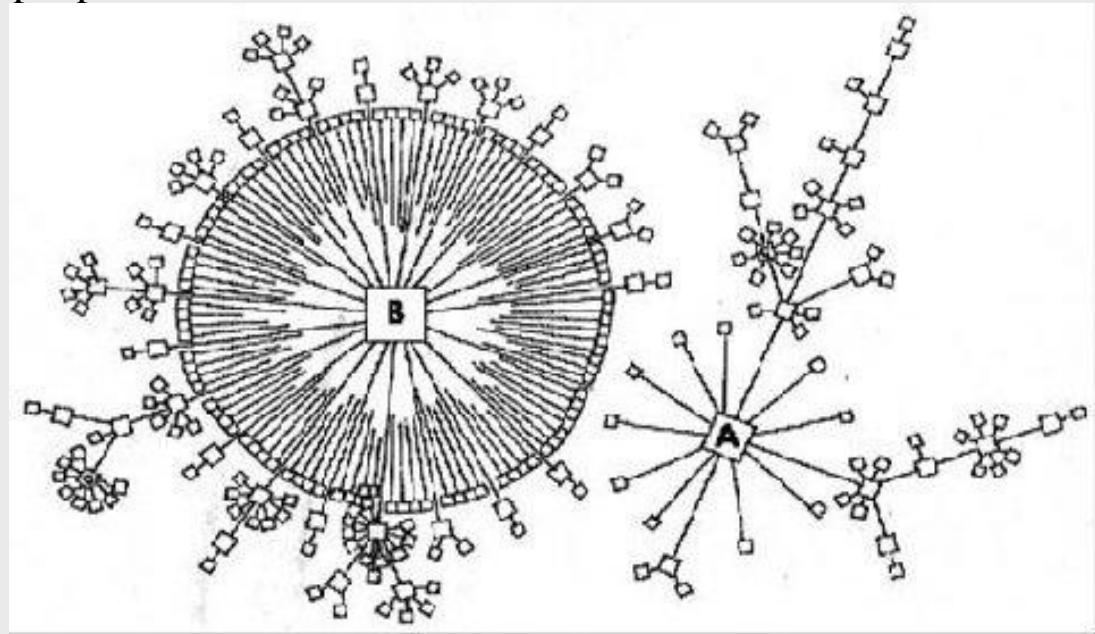

2.3 Three Text Perspectives (cont.)

Analysis on the holistic and most complex description level accounts for ‘gestalt’ phenomena in individual texts and structures them as (implied) holistic systems (holons) of knowledge, culture and/or values (‘constellations’, Floros 2003). It is generally recognized that understanding texts requires world knowledge in interaction with what is verbalized in the text. This interaction is made transparent by relating system and text in the form of ‘concretizations’ which allow for identifying individual (coherence-establishing) inferences and transparency of interpretations of a text.

Representation and visualization is by thesaurus or semantic networks.

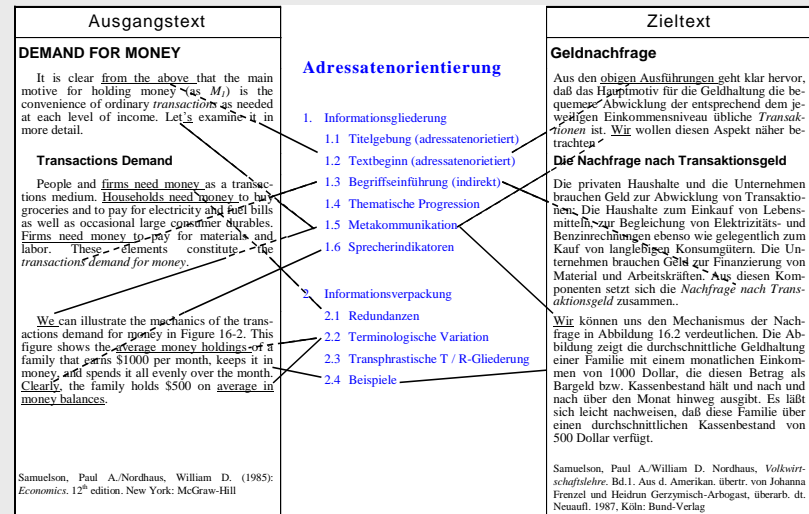

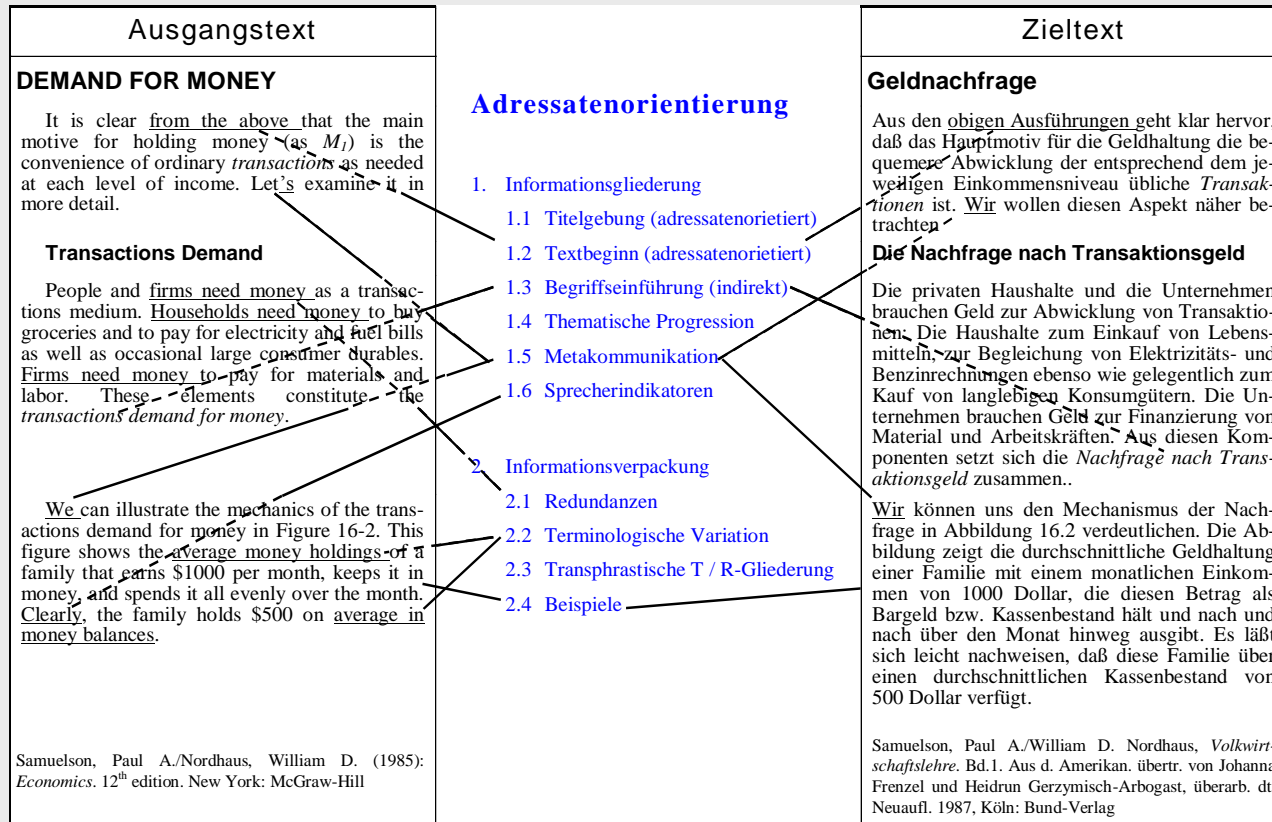

3 Die musikalische Fokussierung (Musical Focussing)

From Jan Kunold:
Translating Music

I. Hervorhebung

- I.1 Rein textuelle Hervorhebung**
 - I.1.1 Wiederholung
 - I.1.2 Satzmarkierung
 - I.1.3 Interjektion
 - I.1.4 Interpunktion
- I.2 Rein musikalische Hervorhebung**
 - I.2.1 betonte Taktzeit
 - I.2.2 markierte Rhythmik
 - I.2.3 unerwartete harmonische Wendung
 - I.2.4 unvorbereiteter Einsatz
 - I.2.5 lange Tondauer
 - I.2.6 musikalische Wiederholung
- I.3 Musikalische und textuelle Hervorhebung**
 - I.3.1 getreue Wiederholung (Text und Noten)
 - I.3.2 variierte Wiederholung
 - I.3.3 lautmalerische Gestaltung

20. *„Ihr Werk hat mir ge - fal - len.*

21. *eu - er Werk hat mir ge - fal - len;*

22. *und das la - be Ma - den er - ght -*

23. *Al - len ei - ne gu - te Nacht.*

24. *Al - len ei - ne gu - te Nacht.*

25. *Hilf' ich tau - send Ar - me zu rüh - ren!*

GERMAN

I. Hervorhebung

- I.1 Rein textuelle Hervorhebung**
 - I.1.1 Wiederholung
 - I.1.2 Satzmarkierung
 - I.1.3 Interjektion
 - I.1.4 Interpunktion
- I.2 Rein musikalische Hervorhebung**
 - I.2.1 betonte Taktzeit
 - I.2.2 markierte Rhythmik
 - I.2.3 unerwartete harmonische Wendung
 - I.2.4 unvorbereiteter Einsatz
 - I.2.5 lange Tondauer
 - I.2.6 musikalische Wiederholung
- I.3 Musikalische und textuelle Hervorhebung**
 - I.3.1 getreue Wiederholung (Text und Noten)
 - I.3.2 variierte Wiederholung
 - I.3.3 lautmalerische Gestaltung

20. *"You have done your la - bor brave - ly!*

21. *you have done your la - bor brave - ly!"*

22. *And the maid - en, my de - light, -*

23. *Wish - es all a kind good night,*

24. *Wish - es all a kind good night.*

25. *Had I might - y arms with - out num - ber,*

ENGLISH

3. Applications & Preview

The text perspectives and methodologies are roughly presented in a wide range of applications: translating literature, film, music and websites as well as interpreting. The subsequent doctoral presentations will apply these principles to their projects showing their explanatory power for translation and interpreting.

11:15 – 12:00	Georgios Floros (Cyprus) Cultural constellations and translation
12:00 – 12:45	Min Sunwoo (Bonn/Saarbrücken) Operationalizing the translation purpose (Skopos)
12:45 – 14:00	— Lunch —
14:00 – 14:45	Martin Will (Saarbrücken) Knowledge Management for Simultaneous Interpreters in LSP Conferences
14:45 – 15:30	Daniel Dejica (Timisoara) Thematic Information and Text Perspectives
15:30 – 16:00	— Coffee Break —
16:00 – 16:45	Jan Kunold (Saarbrücken) Translating Musical Texts
16:45 – 17:30	Lihua Jiang (Saarbrücken/Sichuan) Identifying Parameters in 'Discourse Interpreting'
17:30 – 18:15	Sandra Nauert (Saarbrücken) Translating Websites